

Leister WELDPLAST S4 / WELDPLAST EC4 Hand extruder



Please read operating instructions carefully before use and keep for further reference.

APPLICATION

Welding PE and PP thermoplastics for applications in

- container engineering
- plastic fabrication
- pipeline construction
- landfill sites

WELDPLAST S4

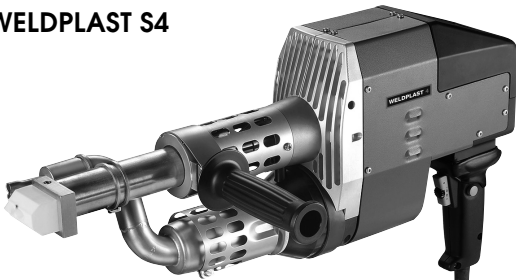

WELDPLAST EC4

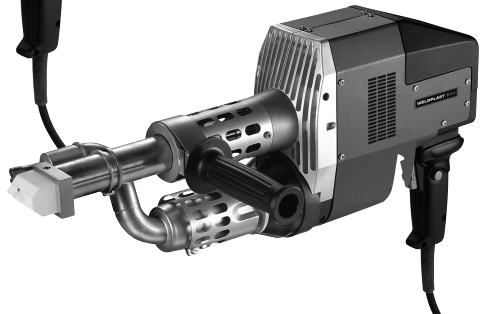



WARNING



Danger to life!

Danger to life when opening up the tool, as live components and connections are exposed. Before opening the tool, unplug from the mains supply. Electrically conducting material (e.g. PE-EL) must not be welded.



Fire and explosion hazard with incorrect use of the hand extruder (e.g. overheating of the material), especially near combustible materials and explosive gases.



Danger of getting burned! Do not touch exposed metal parts and escaping plastized material. Do not point the hot air flow and escaping plastized material in the direction of people or animals.



Connect the tool to a **mains socket with protective earth**. Every interruption of the protective earth inside or outside of the tool is dangerous!

Only use extension cables with protective earth!



CAUTION



The **voltage rating** stated on the name plate of the tool must correspond to the mains voltage.







For personal protection on building sites we **strongly recommend** the tool to be connected to a RCCB (Residual Current Circuit Breaker).



The tool must be operated under supervision. Heat can reach combustible materials, which are out of sight.



Protect tool from **dampness and wet**.

TECHNICAL DATA		WELDPLAST S4	WELDPLAST EC4
Voltage	V~	230	230
Power consumption	W	3680	3680
Frequency	Hz	50/60	50/60
Air flow (20°C)	l/min	approx. 400 with no. 2 nozzle	approx. 400 with no. 2 nozzle
Air temperature	°C	max. 350	max. 350
Plasticizer temperature	°C	max. 260	max. 260
Welding output * Ø 3	kg/h	PE 1.5–2.2 PP 1.4–1.9	PE 0.7–2.3 PP 0.5–2.0
Welding output * Ø 4	kg/h	PE 2.2–3.8 PP 2.2–3.4	PE 1.1–3.7 PP 1.1–3.7
(*average values at 50 Hz)			
Welding rod	mm	Ø 3 / Ø 4 ±0.2 (in accordance with DVS 2211)	Ø 3 / Ø 4 ±0.2 (in accordance with DVS 2211)
Size L × B × H	mm	560 × 110 × 300 (without welding shoe)	560 × 110 × 300 (without welding shoe)
Weight	kg	8.7 (without cable to mains)	10.5 (without cable to mains)
Marking of conformity		CE	CE
Approval mark			
Certification scheme		CCA	CCA
Protection class I			

Description of tool

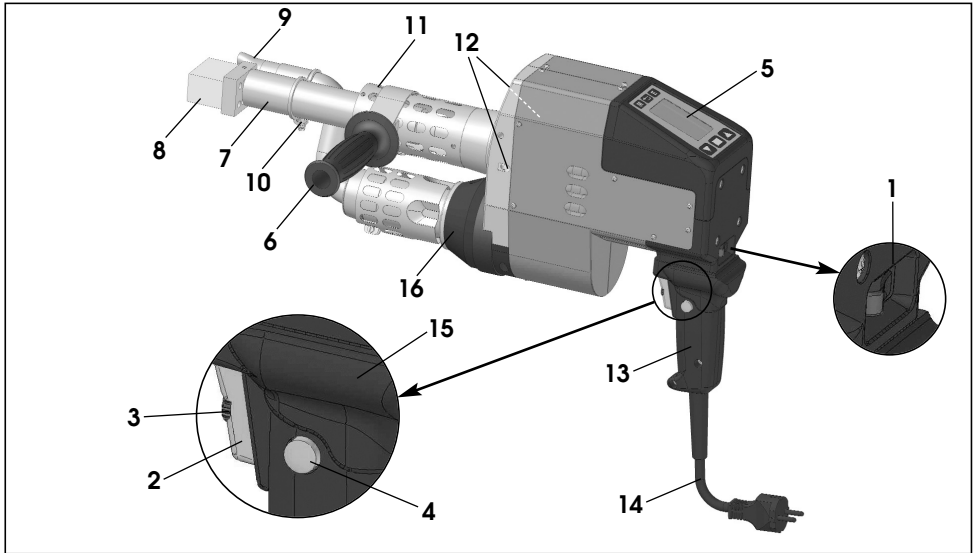

- | | |
|-----------------------|------------------------|
| 1 Main switch | 9 Pre-heating nozzle |
| 2 Motor on/off switch | 10 Tube clamp |
| 3 Potentiometer | 11 Protective tube |
| 4 Locking device | 12 Welding rod opening |
| 5 Display | 13 Tool handle |
| 6 Handle | 14 Mains cable |
| 7 Jacket heating | 15 Hand protection |
| 8 Welding shoe | 16 Hot-air blower |

Operating unit

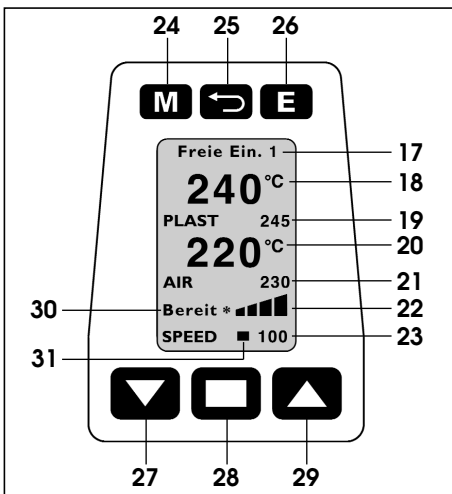

- | |
|---------------------------|
| 17 Welding program |
| 18 Actual value plast |
| 19 Set value plast |
| 20 Actual value air |
| 21 Set value air |
| 22 Bar display |
| 23 Welding output display |
| 24 Menu key |
| 25 Back key |
| 26 Enter key |
| 27 Down key |
| 28 Select key |
| 29 Up key |
| 30 Status display |
| 31 Cursor |

Working environment / safety



The hand extruder must not be used in inflammable environments or where explosion hazards exist. Ensure stable positioning during operation. The connection cable and the welding rod must remain unimpeded and must not hinder the user or others during operation.



Rest the hand extruder on a fireproof surface! Hot metal parts and the hot-air jet must have sufficient clearance from the surface and walls.

Adjusting the handle

The clamp is loosened by turning the plastic handle counter-clockwise and the handle can be positioned in the ideal working position by sliding back or forwards. The handle can also be rotated for left/right handed users (see also Welding direction left/right)

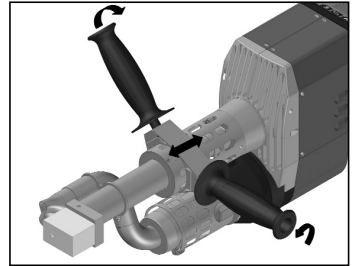

Workstation

For starting operation of the hand extruder and setting it down, Leister offers a comfortable **universal tool stand** with integrated hot-air hood and welding rod dereeler holder (see Accessories).

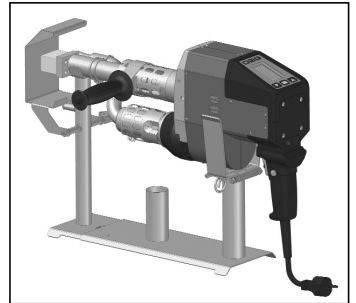

In the case of interruptions to welding work, the drive motor can be switched off with the **motor on/off switch (2)**. Place the hand extruder with the handle appropriately positioned and tightened on a stable fireproof surface as illustrated.

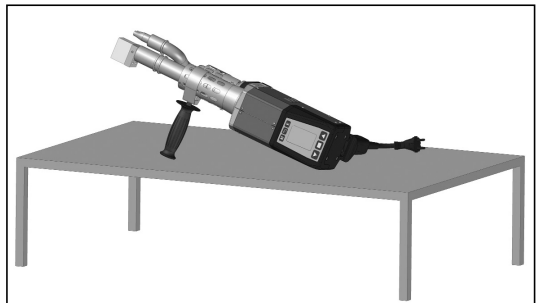

Power supply

When using an extension cable, take care to ensure the minimal cable cross-section:

Length (m)	Minimum cross-section (at ~230V) (mm ²)
Up to 19	2.5
20-50	4.0

Extension cables must be approved for the working environment (e.g. outdoors) and labelled accordingly.

If a generator is used to supply electricity, the rated power of the generator must be 2x the rated power of the hand extruder.

Starting procedure

Temperature monitoring prevents the hand extruder starting up in a cold state.

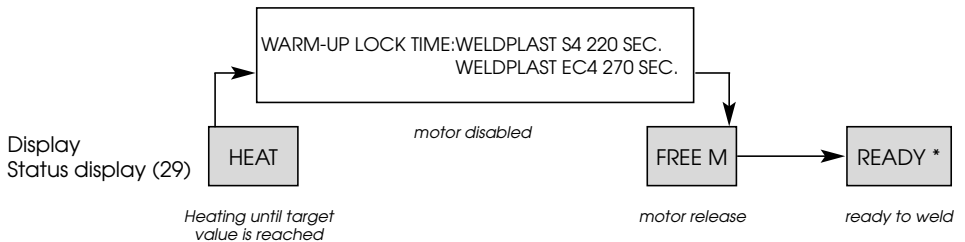

The tool starts immediately by heating up to the target temperatures last set. A counter in the status display then counts down the warm-up lock time of 220 sec. The hand extruder reaches its operating temperature (READY* status) after approx. 8 minutes. On completion of the starting procedure the tool is ready to weld.

Software and menu navigation

The Weldplast hand extruder comes equipped with comfortable operating software, which simplifies operation for the user and makes it easier to handle the extruder.

Key functions

The keys respond with gentle keystrokes.

• Operating window

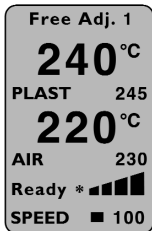

Operating window functions	
	Menu selection
	Set contrast
	Heating on/off
	Change cursor position
	Selected parameter (+)
	Selected parameter (-)

• Menu selection

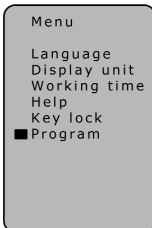

Menu selection functions	
	Menu selection / return to operating window
	Return as ESC (changes are not saved!)
	Select and return to operating window
	Select
	Cursor up / selected parameter +
	Cursor down / selected parameter -

Preparation for welding

Start window

After switching on the extruder, the name of the tool and the current software version are displayed for 3 sec.



Operating window

The operating window shows the parameters currently set.

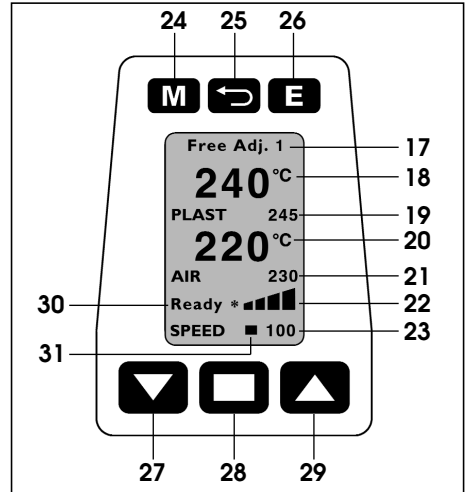

Setting parameters in the operating window

The **cursor (31)** shows which parameters can be set. After switching on, the cursor is on the «**SPEED**» position.

In the operating window, the following parameters can be selected with the **Select key (28)** and changed in their values with the **Up (29)** and **Down keys (27)**.

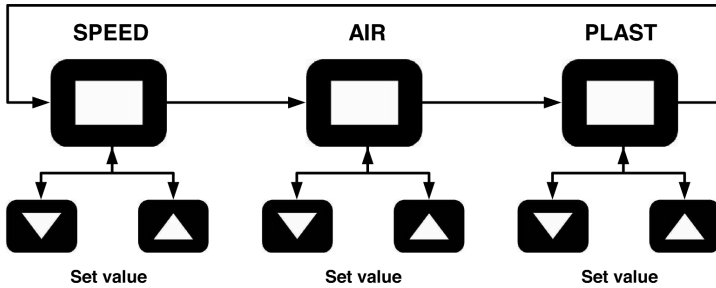

Setting the welding output

A variable welding output allows seam thickness and pre-heating times to be coordinated.

Presetting on the display

- Set the cursor to the «**SPEED**» position by pressing the **Select key (28)**.
- Define the maximum welding output value (30 to 100) with the **Up (29)** or **Down (27)** keys

Fine tuning during the welding process

By turning the **potentiometer (3)**, the welding output set can be reduced from the maximum value (e.g. 85) to the minimum (displayed on the **display bars (22)**).

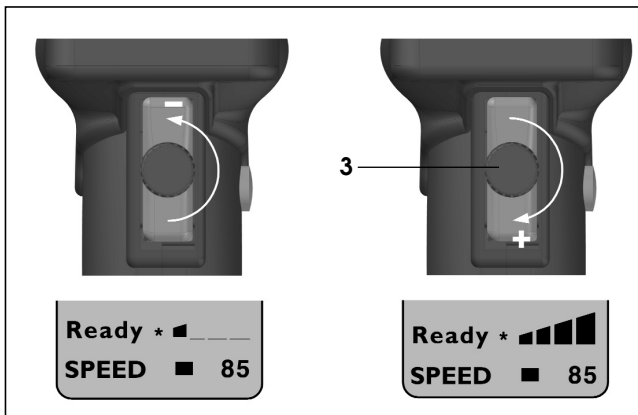

The plastized material throughput is also dependent on the welding rod thickness used. If the welding output is too high with the output display "30" and the potentiometer is set to "minimum", the next smallest welding rod thickness must be selected. 9

Setting the PLAST and AIR temperatures

- Set the cursor to the «PLAST» or «AIR» position by pressing the **Select key (28)**.
- Set the temperature value with the **Up (29)** or **Down (27)** keys.

Monitoring the welding parameters

The set and actual values of the AIR and PLAST temperatures are continuously monitored. If the actual value deviates from the respective set value (value outside the tolerance band), this is indicated on the **status display (30)** with a status change. If necessary, the drive motor is temporarily disabled until the welding parameters are once again within the prescribed tolerance band. The possible status displays and the tolerance bands may be seen in the following graph and table.

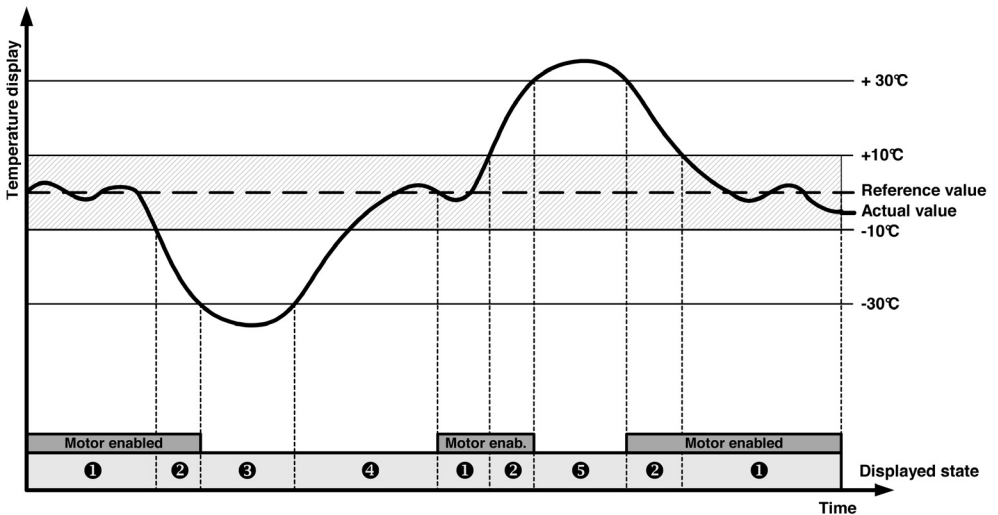
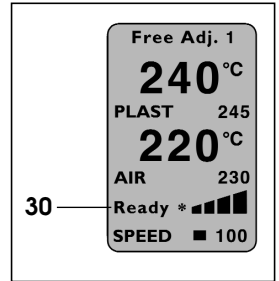

No.	Status display	Status properties
1	Ready *	Ready to weld
2	M enabled	Deviation of the welding parameters > -10°C
3	Heat	Deviation of the welding parameters > -30°C, drive motor disabled
4	S4: 220s EC4: 270s	Warm-up lock time of 220 sec., drive motor disabled Warm-up lock time of 270 sec., drive motor disabled
5	Too hot	Deviation of the welding parameters > +30°C, drive motor disabled

Starting the welding process

Welding work should comply with German Welding Association (DVS) guidelines.

- Fit the appropriate **welding shoe (8)** as required.
- Set the **potentiometer (3)** to max.
- Once the operating temperature is reached («READY*» status), welding can begin.
- Activate the **motor on/off switch (2)**.
- Insert welding rod with a diameter of 3 or 4 mm into the **welding rod opening (12)**.
- The welding rod is automatically drawn in through the **welding rod opening (12)**. The rod should feed in without resistance.



CAUTION!

Never insert into both welding rod openings simultaneously. Never operate the tool without welding rod.

- Interrupt the passage of plastized material with the **motor on/off switch (2)**.
- Direct the **pre-heating nozzle (9)** towards the welding zone.
- Preheat the welding zone with a fanning motion.
- Place the tool over the prepared welding zone and reactivate the **motor on/off switch (2)**.
- Produce a test weld and analyse it.
- Adjust the temperature setting and welding output as required.
- For a prolonged welding process, the **motor on/off switch (2)** can be kept in continuous operation by means of the **locking device (4)**.

Switching off the tool

- Release the **locking device (4)** of the **motor on/off switch (2)** as applicable, and then let go of the **motor on/off switch (2)**. Remove welding material in the welding shoe in order that the welding shoe is not damaged with the next start
- Switch off the heating with the **button (26)** "Enter".
- Let the tool to cool down for approx. 5 min.
- Switch off at the **main switch (1)**.

Further settings

Contrast setting



Given unfavourable lighting conditions and fluctuations in the ambient temperature, the contrast on the display can be set in the operating window with the **back key (25)**.

Heating on/off



In the case of long interruptions (standby), the heating for PLAST and AIR can be deactivated with the **enter key (26)** in the operating window.

Activate key lock

1. Menu



2. Key lock



3. Activate



If the key lock has been activated, key lock appears in the display.

The lock can be reset as follows:

Deactivate key lock

1. Back



2. Reset



3. Select



Confirmation with the Select key must immediately follow the reset!

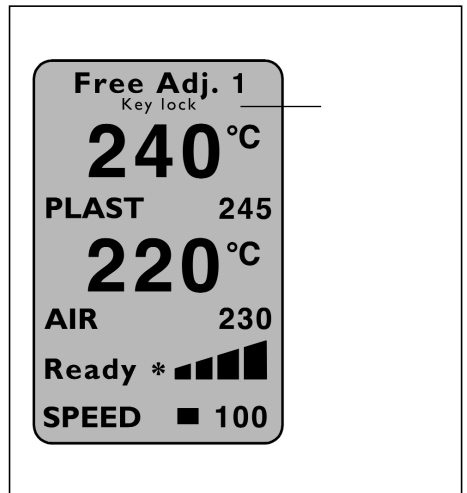

Menu navigation

Menu

Menu



Scroll



Select



Functions

Scroll







Select and return

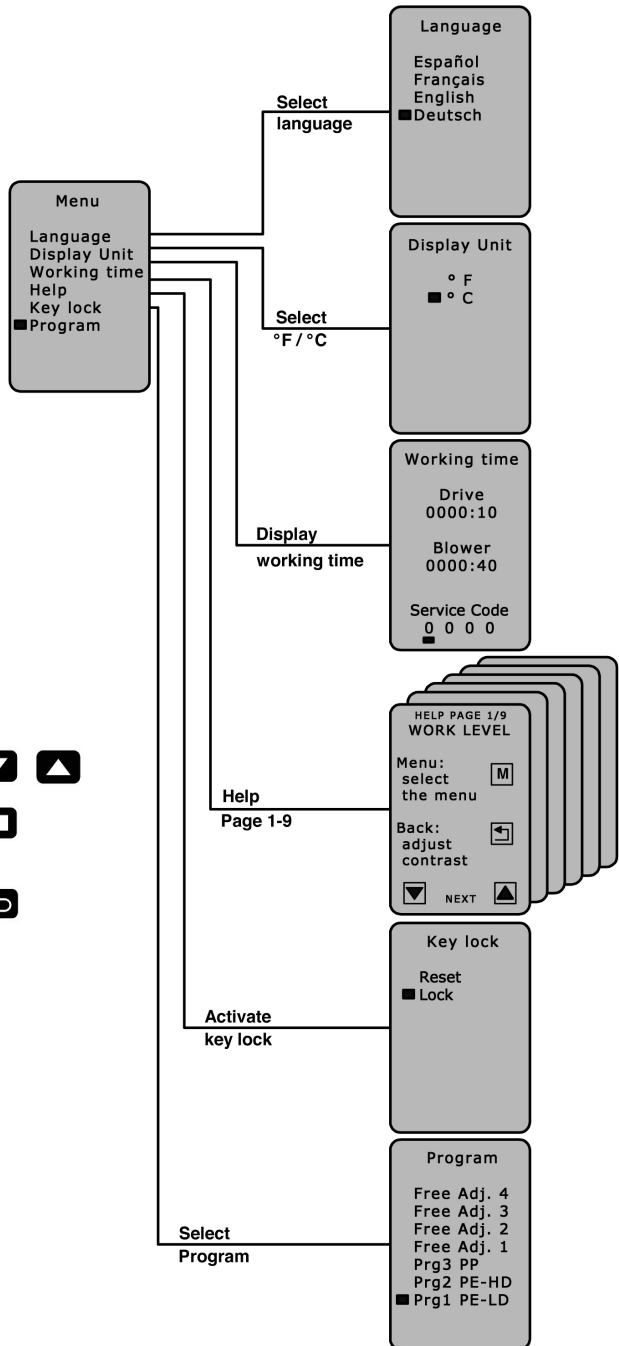

Return to operating window
Scroll



Welding parameters – Programming

Menu	
Select program	
Scroll	 
Enter	

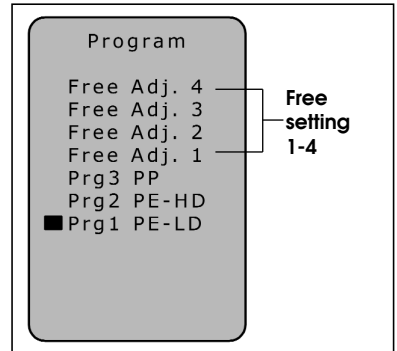

The hand extruder is suitable for the following types of thermoplastic: • PP/PE-HD/PE-LD

Programs 1 – 3 include the relevant preset values, which can be adjusted during the course of the welding process.

The adjustments are not saved!

The free settings 1 - 4 are factory set and can be freely programmed. The parameters remain saved after the tool is switched off.

Welding program	Target PLAST (°C)	Target AIR (°C)
Free settings 1 – 4	230	260
Prg1 PE-LD	220	260
Prg2 PE-HD	230	260
Prg3 PP	230	260

The **welding program (17)** currently set is shown in the operating display.

Setting the welding output

- Place the cursor on the «SPEED» position by pressing the **Select key (28)**.
- Set the welding output value (30 to 100) with the **Up (29)** or **Down keys (27)**.

Setting the PLAST and AIR temperature

- Place the cursor on the «PLAST» or «AIR» position by pressing the **Select key (28)**.
- Set temperature value with the **Up (29)** or **Down keys (27)**.

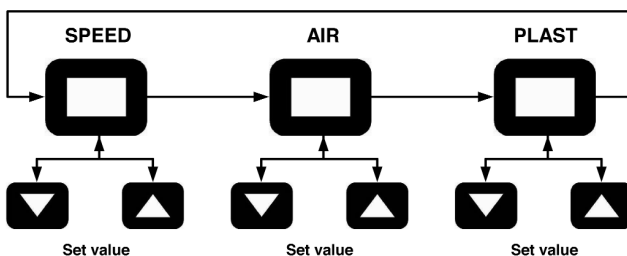

Replacing the welding shoe

- The welding shoe must only be replaced when the tool has attained its operating temperature.



**Work with temperature resistant gloves only.
Danger of getting burned!**

- Switch off the tool at its operating temperature and disconnect it from the mains supply.
- Remove the **complete welding shoe (8)** by loosening the **screws (35)** from the **extruder nozzle (32)**.
- Clean the **extruder nozzle (32)** each time the welding shoe is replaced and remove any welding deposits.
- Attach an appropriate welding shoe.

Disassembling the welding shoe

- The **welding shoe (36)** can be removed by unscrewing the **clamping bolts (33)** from the **welding shoe holder (34)**. (e.g. for reworking)

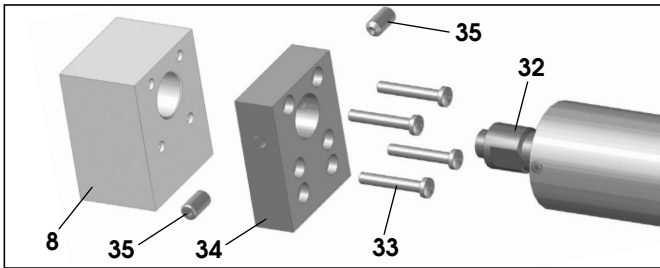

8 Welding shoe
32 Extruder nozzle
33 Welding shoe clamping bolts

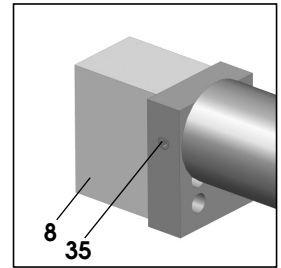

34 Welding shoe holder
35 Welding shoe holder set screw

Welding direction

Orientation of the **pre-heating nozzle (9)** for different welding directions

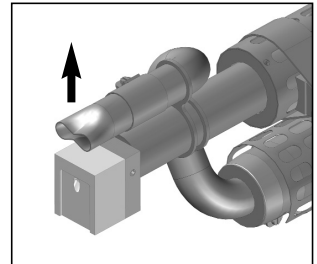
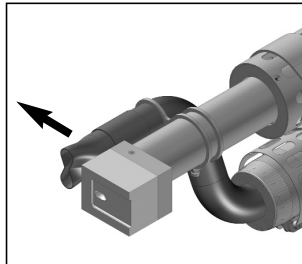
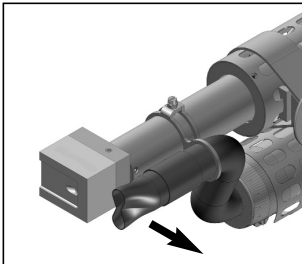

With the standard hot-air tube the nozzle can be mounted either left or right.

With the optional hot-air tube the nozzle is mounted on top.

Pre-heating nozzles

There are three different **pre-heating nozzles (9)** available according to the required welding seam width. The nozzle cross-sections comply with DVS guidelines.

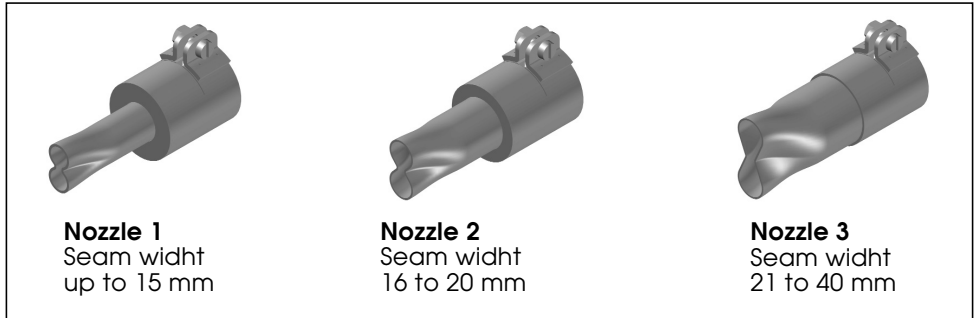

Replacing the pre-heating nozzles

To disassemble the pre-heating nozzle, loosen the **clamping screw (43)** on the side and pull the **pre-heating nozzle (9)** off the **hot-air tube (44)**. To ensure no pre-heated air is lost, the nozzle is pushed on the **hot-air tube (44)** as far as it goes. Take care that the nozzle is parallel to the nozzle shoe.



**Work with temperature resistant gloves only.
Danger of getting burned!**

Replacing the hot-air tube

To disassemble the **hot-air tube (44)**, firstly remove the **welding shoe (8)**. After loosening the countersunk **locating screw (45)** on the tube **clamp (10)** and the **clamping screw (47)** on the hot-air tube connector, the complete unit can be removed.

Assembly in the reverse sequence.

To ensure no pre-heated air is lost when reassembling, the unit must be pushed on the **hot-air blower (16)** as far as possible.

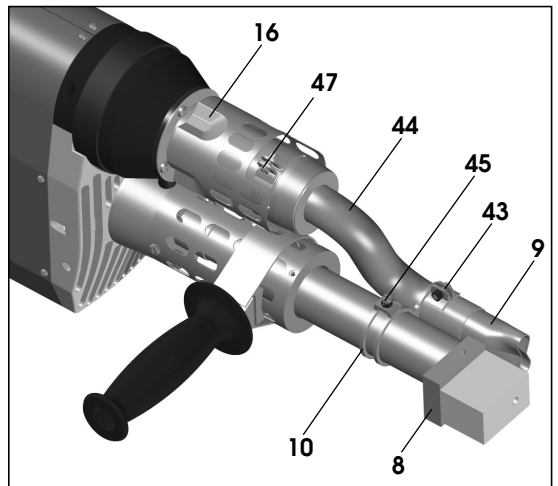

Error messages

An error occurring is shown in the status display (29) (e.g. **Err04** Motor is overheated).

Display **ErrXX**

When an error occurs, the heating units for AIR and PLAST, as well as the drive motor, are switched off immediately!

Should this not take place, the tool must be disconnected from the mains supply immediately!

Further procedure with status display (29) **ErrXX**

- Note down the error code
- Release the **locking device (4)** of the **motor on/off switch (2)** as applicable and then let go of the **motor on/off switch (2)**.
- Switch off the tool at the **main switch (1)**.
- Start using the tool again under supervision and ensure that the extruder is not overheated from the outside.
- Eject the remaining plastic from the screw if possible.
- Should the error reoccur, the tool should be sent to the Service Centre to be checked, specifying the error code.

The following errors are recognised by the tool:

Display	Type of fault
Err01	Overheating of the air or defective temperature probe
Err02	Overheating of the plastic welding material or defective temperature probe
Err04	Overheating of the motor winding, motor is overheated
Err08	Overheating of the heating element, AIR or failure of the blower motor
Err10	Overheating of the electronics
Err40	Short circuit of the PLAST temperature probe

Several errors can occur at once

e.g. **Err02** and **Err04** Display: **Err06** !

Further combinations are displayed with the letters A, B, C, D, E and F.

e.g. **Err08** and **Err02** Display **Err0A** !

Drive overheating protection

If the drive is overheated by external influences or because the PLAST temperature is too low, the internal temperature protection of the drive switches off (see **Err04**.)

False start protection

The drive motor is protected against autonomous starting following faults, **Err04** overheating. The message "Switch off motor" appears in the **display (5)** while the drive motor remains in the blocked state. After rectifying the fault and switching off the motor, **motor on/off switch (2)**, the message "Switch off motor" disappears from the **display (5)**. Work may then continue.

Only Leister accessories may be used.

The **universal tool stand** can be used for the following extruder lines:

- Fusion 3
- Weldplast 4
- Weldplast 6

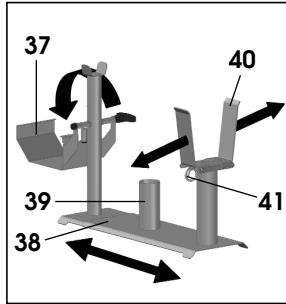

- The **hood (37)** is swivelled upwards for pre-heating the welding shoe.
- To adjust the stand, loosen the screws in the base and adjust the **base plates (38)** to the tool markings.
- The two **sliders (40)** allow the width to match the required tool.
- The **reel holder (39)** serves to hold the reels of welding rod \varnothing 300 mm.
- To ensure optimal rod dispensing, the welding rod should be passed through the **eyelets (41)** provided.

Transportable welding rod dereel holder

- The holder is designed for two welding rod reels with \varnothing 300 mm
- To ensure optimal rod dispensing, the welding rod should be passed through the **eyelets (41)** provided.

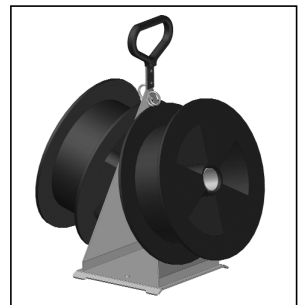
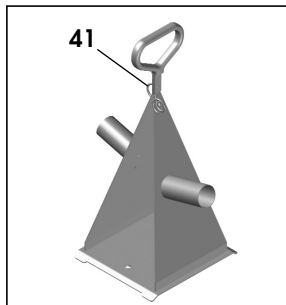

Hot - air tube on top

- The hot air tube is especially suited for landfill sites.

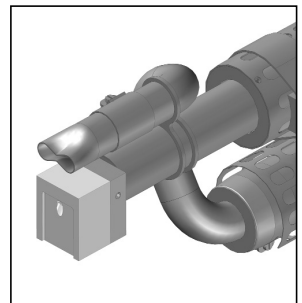
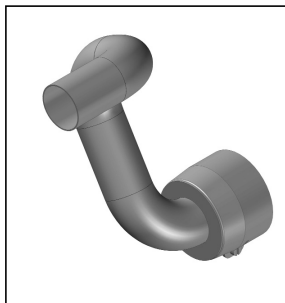

The Leister range

Leister offers welding shoes for all the common seam geometries in various sizes:

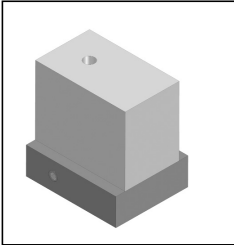
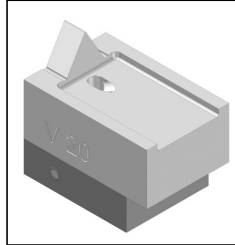
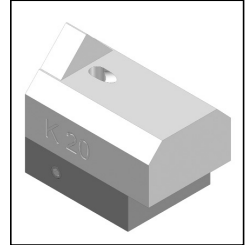
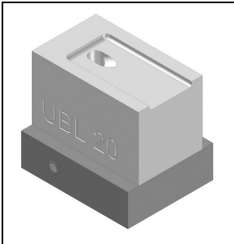
**Blank****V weld****Fillet weld****Overlap weld**

MAINTENANCE

- Check the **power supply cord (14)** and plug for electrical and mechanical damage.
- Clean the **extruder nozzle (32)** each time the welding shoe is replaced and remove any welding deposits.

SERVICE AND REPAIR

- Repairs should only be carried out by authorized **Leister Service Centres**. They guarantee a specialised and reliable **Repair Service within 24 hours** using original spare parts in accordance with the circuit diagram and spare parts list.
- If the service message appears with the **Service Code 1** after switching on WELDPLAST S4, the state of the carbon brushes should be checked by an authorised **Leister Service Centre** and the carbon brushes replaced, if necessary.
- The display can be removed with the  **key (28)**.
- The extruder can be used again for a short time.
- If the carbon brushes are not replaced within a short time, the motor will run until the mechanical brush reaches its limit stop. No more error messages appear on the display, the motor no longer runs.
- WELDPLAST EC4 has a brushless drive motor. For this reason **Service Code 1** does not appear.

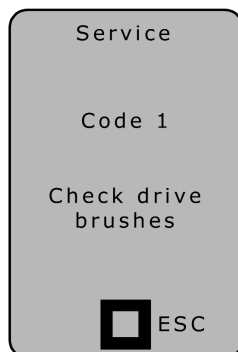

GUARANTEE AND LIABILITY

- Guarantee and liability are in accordance with the guarantee certificate as well as the currently valid general conditions of business and terms of delivery.
- Leister Process Technologies rejects any guarantee claims for tools, which are not in their original condition. Tools must never be altered or changed.

Technical data and specifications are subject to change without prior notice

Your authorized Service Centre is: