

The new MISTRAL: The incomparable hot-air blower.

Two model groups are available in this range – the MISTRAL², ⁴, and ⁶ PREMIUM, and the top-of-the-range MISTRAL⁶ SYSTEM. All MISTRAL⁶ devices are equipped with a maintenance-free brushless blower motor, making them perfectly-suited to continuous operation. The MISTRAL⁶ SYSTEM can either be operated using its integrated controls or via an external system interface.

Hot-air blower

New

MISTRAL PREMIUM / SYSTEM

1		Maintenance-free Thanks to its brushless motor, the new MISTRAL ⁶ PREMIUM / SYSTEM is perfectly-suited to continuous operation
2 / 3		Innovative: Using the "e-drive" operating unit, the air volume and temperature for the MISTRAL SYSTEM can be adjusted to suit every application. Fully-integrated: Main switch with integrated function pushbutton for programming (MISTRAL SYSTEM).
4		Multifaceted: Can be operated as a device with integrated control or via an external system interface for integration into a closed-loop system (MISTRAL SYSTEM).
5		Informed: Display with user status information and programming (MISTRAL SYSTEM).



MISTRAL SYSTEM

	PREMIUM			SYSTEM
	2	4	6	6
Brushless blower motor			•	•
Brush motor with replacement carbon brushes		•		
Brush motor	•			
Integrated heating element and tool protection	•	•	•	•
Integrated code switch for potentiometer (internal / external)	•	•	•	
Infinitely adjustable heating capacity and air volume with the "e-drive"				•
Automatic cool-down function				•
Remote control interface for temperature / air volume				•
Integrated temperature probe				•
Target / actual values display				•

6		Innovative design: Special baffle for an even airflow distribution and an optimised, aerodynamic airflow velocity.
7		Integrated: Thermal probe in the MISTRAL SYSTEM for enhanced precision.
8		Quick to connect: Thanks to the integrated air-hose connection adapter with its internal 1-inch thread, an additional adapter is not required.
9		Convenient: Its state-of-the-art industrial design and convenient mounting tabs are sure to impress.
10		Automatic cooling: The MISTRAL SYSTEM is equipped with an automatic cool-down function. In the MISTRAL PREMIUM, the blower and heater can be controlled separately.
11		Easy to switch: The MISTRAL PREMIUM can be switched from an internal to an external potentiometer (optional). As a result, the temperature can even be controlled from the outside.

Hot-air blower

MISTRAL PREMIUM / SYSTEM



MISTRAL PREMIUM

Installation dimensions in mm

	A	B	C
230V / 2300 W 100V / 1500 W	∅ 36,5	106.6	321
230V / 4500 W	∅ 50	137,5	352
230V / 3400 W 120 V / 2400 W 200 V / 3000 W	∅ 50	107.8	322.2

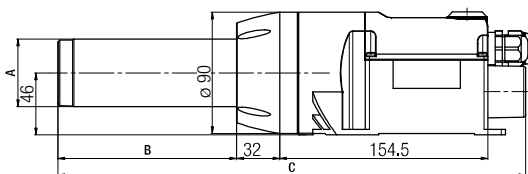
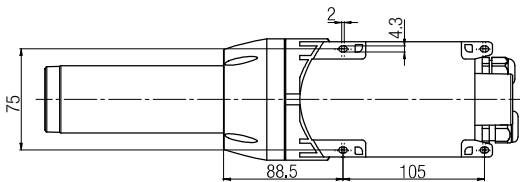
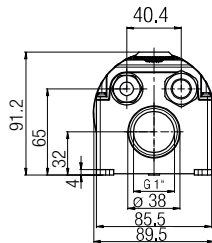

Technical data	MISTRAL 2, 4, 6 PREMIUM						
	Model	2	4	6	6	6	6
Voltage	V~	230	120	120	230	230	230
Power	W	3400	2400	2400	2300	3400	4500
Temperature open	°C	520	490	430	500	510	650
Max. air volume (20 °C)	l/min.	350	300	350	300	350	400
Pressure	kPa	3.5	3.5	2.5	2.5	2.5	3.0
Weight	kg	1.4	1.4	1.4	1.4	1.4	1.5
∅	mm	50	50	50	36.5	50	50
Article no. MISTRAL 2, 4, 6 PREMIUM		147.963	147.964	147.965	148.006	147.966	147.967

Model	MISTRAL 6 SYSTEM						
		100	120	200	230	230	230
Voltage	V~	100	120	200	230	230	230
Power	W	1500	2400	3000	2300	3400	4500
Temperature open	°C	650	650	650	650	650	650
Air volume (20 °C)	min. l/min. max. l/min.	100 300	100 350	100 350	100 300	100 350	100 400
Pressure	kPa	3.5	3.5	2.5	2.5	2.5	3.0
Weight	kg	1.2	1.4	1.4	1.2	1.4	1.5
∅	mm	36.5	50	50	36.5	50	50
Article no. MISTRAL 6 SYSTEM		147.972	147.969	147.973	147.975	146.701	147.968





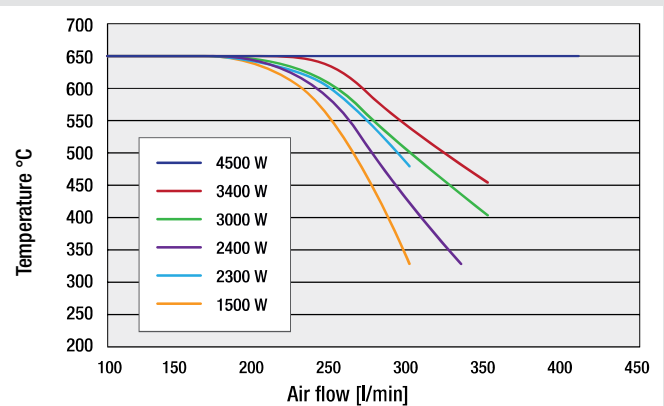

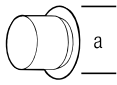
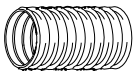
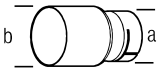

Frequency	Hz	50 / 60
Emission levels	dB (A)	65
Dimensions		see bottom left
Conformity mark		CE
Protection class II		□

We reserve the right to make technical changes

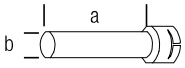
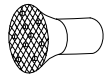
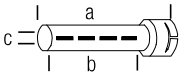
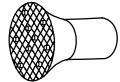
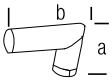

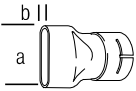
➔ Accessories page 16

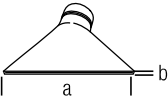
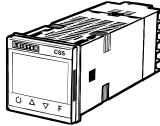
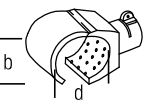
Accessories MISTRAL PREMIUM / SYSTEM (Ø 50 mm)

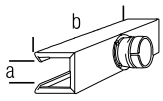
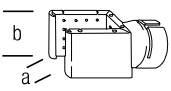
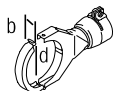
	107.254 Flange connector, push-fit a = 70 mm		107.286 PVC air hose Ø 38 mm
	122.332 122.924 Nozzle adapter, push-fit from (a) Ø 50 mm to (b) Ø 62 mm from (a) Ø 50 mm to (b) Ø 37 mm		107.287 Hose clip for Ø 38 - 60 mm air hose
	107.255 Extension nozzle, push-fit (a × b) 160 × 36.5 mm		106.127 Sieve reflector (Ø 50.5 mm) Ø 65
	105.950 107.257 105.955 105.952 Tubular nozzle, push-fit (a × b × c) 460 × 300 × 2 mm 590 × 420 × 1.47 mm 836 × 660 × 1 mm 900 × 800 × 0.9 mm		107.354 Stainless steel filter, push-fit on air intake
	107.256 Angled nozzle, push-fit (a × b) shank length 106 x 162, Ø 50 mm		106.956 Temperature probe with plug 1 m cable
	105.961 107.258 Wide slot nozzle, push-fit (a × b) 45 × 12 mm, length 350 mm 70 × 10 mm		Temperature probe extension cable with plug 106.958 2 m 106.960 4 m 106.962 10 m
	106.057 106.060 107.270 106.061 Wide slot nozzle, push-fit (a × b) 100 × 4 mm 150 × 6 mm 150 × 12 mm 300 × 6 mm		123.039 CSS – Temperature controller (MISTRAL SYSTEM)
	107.331 Hinged reflector, push-fit (d × b) 70 × 70 mm		148.812 External potentiometer box, analogue, 10 kΩ, with 3 m signal cable (MISTRAL PREMIUM)
	107.340 Shell reflector, push-fit (a × b) 45 × 250 mm		
	107.327 107.333 Sieve reflector, push-fit (a × b) 70 × 75 mm 130 × 150 mm		
	107.330 Hinged reflector, push-fit (d × b) 125 × 22 mm		

Accessories for Ø 36 mm can be found on page 36 (LHS 21 analogue air heaters)