

A

B

1

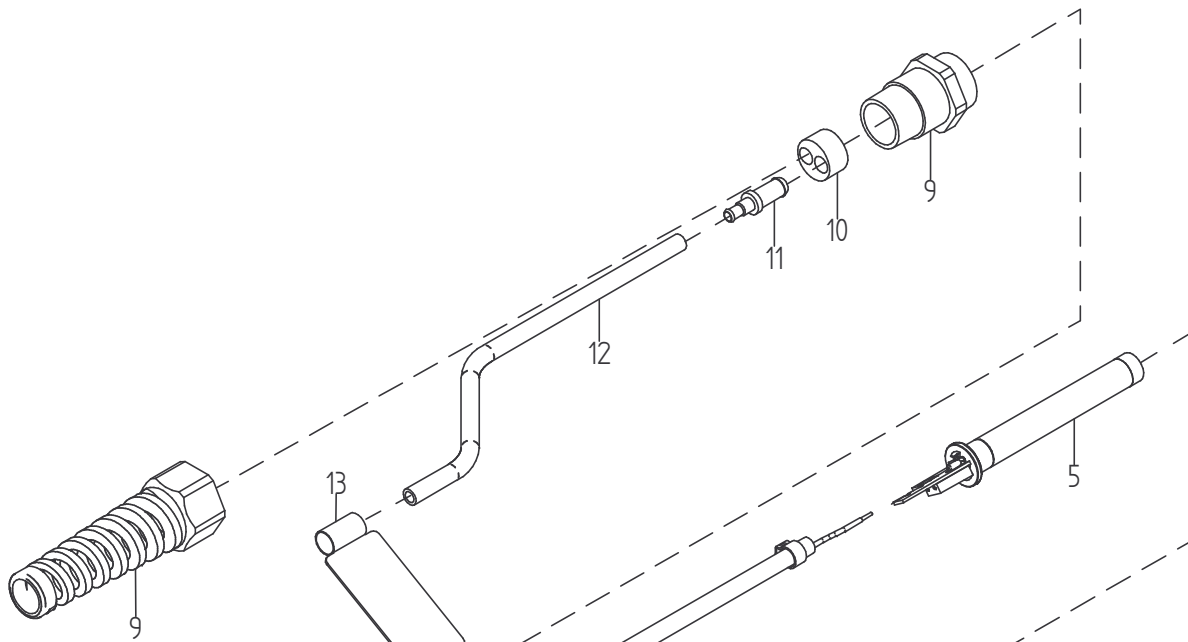

2

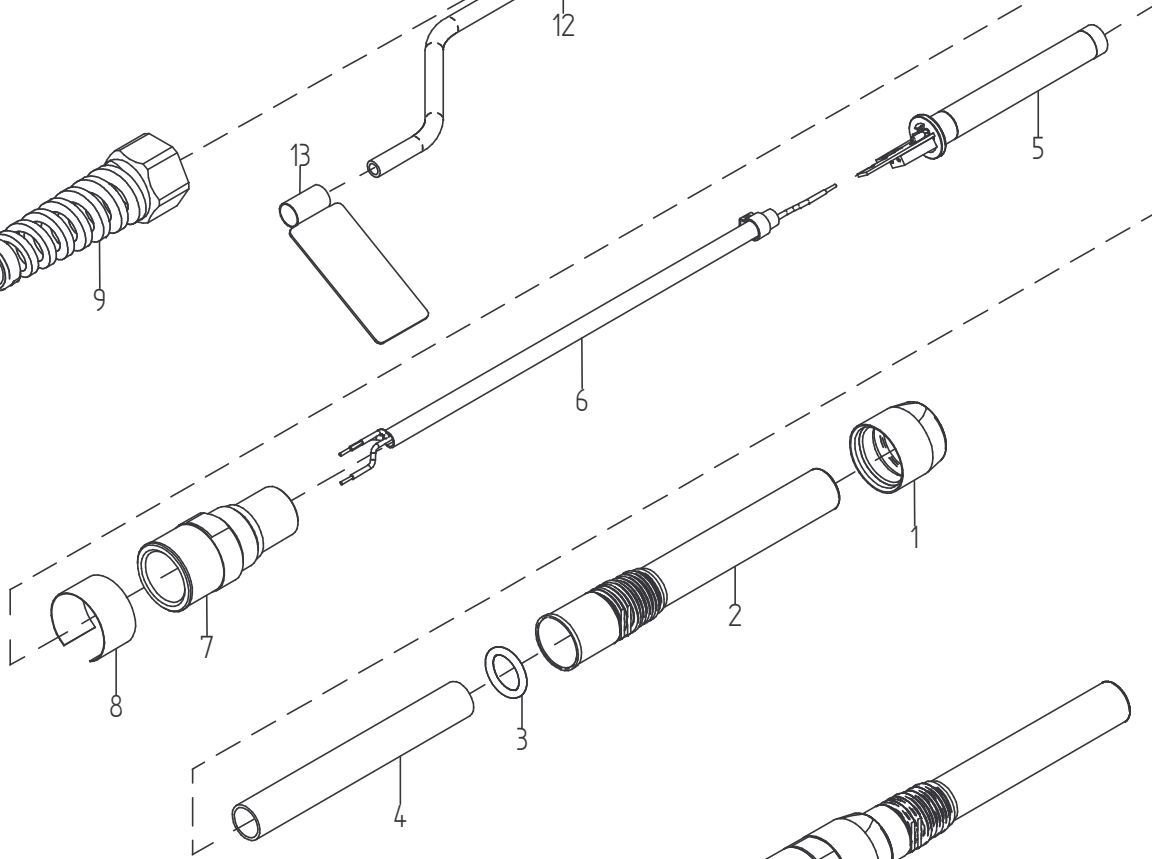

3

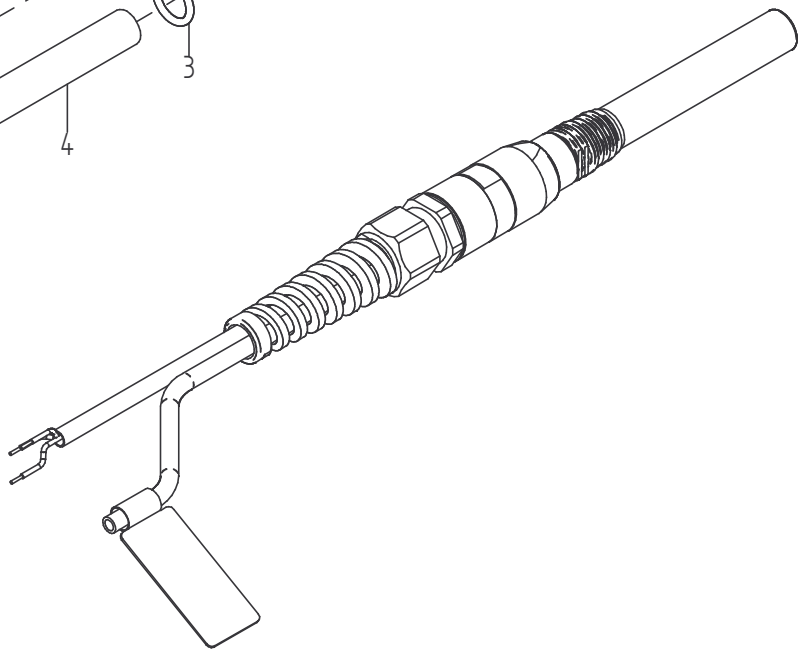

Werkstoff:

Volumen:

Datum Gezeichnet

22.01.2003 H. Arnold

Datum Geprüft

10.12.2003 H. Zurmühle

LE Mini

**LEISTER**  
Process Technologies  
CH-6060 Sarnen

Format

A4

Massstab

%



Zeichnungs-Nr.

11104

Index

A