

LEISTER LE 5000 Electric Hot Air Tool

(without electronics)



Please read operating instructions carefully before use and keep for further reference.

APPLICATION

- The LEISTER Hot Air Tool type 5000 is suitable for building into machines, installations or appliances and is designed for continuous operation.
- **Drying and heating processes** of various types.
- **Shrinking and welding** packaging films and moulded parts.
- **Heating** conveyor ovens or heat tunnels.
- **Activating and loosening** solvent free adhesives and melt adhesives.
- **Sterilizing** packaging materials such as bottles, corks and containers.
- **Separating and fusing** synthetic fibres and fabrics.
- **Soldering processes** on thin metal parts.
- **Speeding up** mixing processes and **dissolving** foams which can arise during mixing and filling operations.
- **Removing** plastic mould flash and putting a **shine** on plastic surfaces.

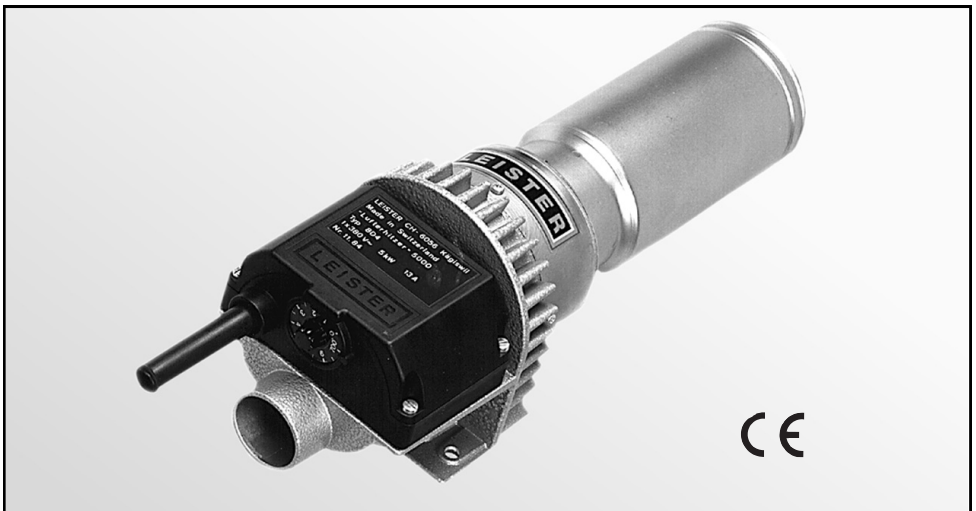



WARNING



Danger! When opening up the tool, live components and connections are exposed. Therefore, before opening it, unplug the tool to ensure disconnection from the mains.



Incorrect installation and use of hot air tools can present a **fire and explosion hazard**. The specified minimum air flow must be absolutely adhered to.



Do not touch the element housing and nozzle when they are hot as they can cause **burns**. Let the tool cool down. Do not point hot air flow in the direction of people or animals.



CAUTION



The **voltage rating** stated on the tool should correspond to the mains voltage.



The tool should be earthed using a protective conductor.



Protect the tool from **damp** and **wet**.



The equipment should not be operated **without supervision**.

TECHNICAL DATA

Voltage	V~	1x220	3 x 220	3 x 220	3 x 220	1 x 380	1 x 380-440
Frequency	Hz		3 x 380	3 x 380	3 x 380		
Capacity	kW	4	4,2	6,0	7,5	5,0	7,5-10
Minimum air flow	l/min	400	450	550	650	500	650-1100
Maximum temperature	°C	700	700	700	700	700	650
Ambient temperature	°C				<100		
Weight	kg				1,7		
Size	mm				318 x 108 x 112		

Description of tool

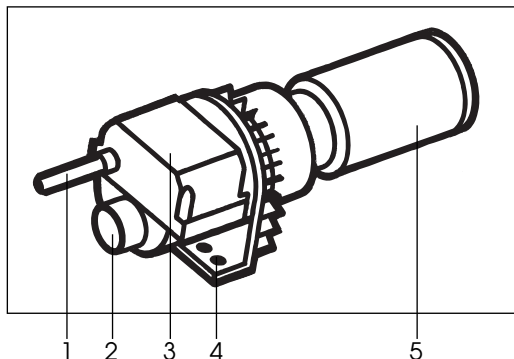

1. Protective sleeve for cable to mains
2. Air intake connection $\varnothing 38$
3. Connection housing
4. Installation stand
5. Element housing with protective sleeve

Installation

- The tool should be fixed by using four M4 screws on the **installation stand (4)**.
- When installing the tool, ensure that:
 - only cold air is sucked in
 - no (warm air) back pressure develops
 - the hot air tool is not in direct line of another hot air tool.
- Protect the tool from vibration and shock.
- Installation dimensions in mm

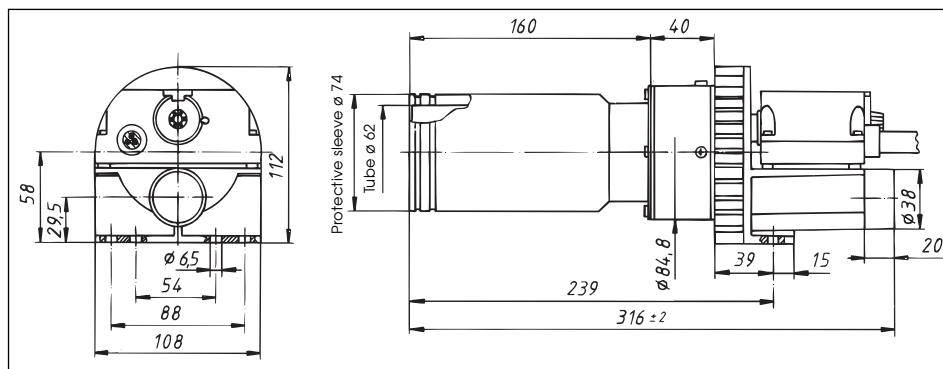

Air supply

- **To protect the tool and the element, the air flow must under no circumstances fall below the specified minimum, and the maximum temperature (measured 3 mm in front of the element housing) must under no circumstances be exceeded. Should the air flow be interrupted or the air flow fall below the minimum, the mains must be disconnected at the same time.**
- LEISTER blowers must be used for the air supply (pay attention to the direction of rotation and the electrical connection).
- For use in a dusty environment the tool should be fitted with a LEISTER stainless steel filter on the air intake connection. Where a particularly critical dust problem exists (eg metal, electrically charged or damp dust) special filters must be used to avoid short circuiting the tool.
- The hot air tool should only be supplied with air up to a max. 100°C.

Operation

- Connect tool to the mains.
- The mains connection cable should have the corresponding cross section area of conductor and should be fitted by a specialist.
- As required, push-fit appropriate nozzle or reflector (see caution).
- Make sure that the hot air can flow freely as otherwise back pressure could damage the tool (fire hazard).
- The LEISTER Company, as well as the authorized Sales and Service Centres, offer advice and an introduction to the areas of application of hot air tools, free of charge (see page 1).
- After use, allow the tool to cool down by letting cold air flow through it (preventing warm air back pressure).

CAUTION:

- * **To protect the tool as well as the element, the minimum air flow (see page 2) must in no way be impeded through nozzles or reflectors.**
- * **The mains connection should have a suitable double pole isolator with a 3 mm distance between contacts.**

ACCESSORIES

- Only LEISTER accessories should be used.
- Let the tool cool down before changing the nozzle or reflector.

SERVICE AND REPAIR

- Repairs have to be carried out by authorised **LEISTER Service Centres** only. They guarantee a specialized and reliable **repair service within 24 hours** using original LEISTER spare parts.

GUARANTEE AND LIABILITY

- Guarantee and liability are in accordance with the guarantee certificate as well as with the currently valid general business and sales conditions.
- LEISTER Process Technologies rejects any guarantee claims for tools which are not in their original condition. The tools must never be altered or changed.

Technical data and specifications are subject to change without prior notice.

Your authorized Service Centre is: