

LEISTER

PROCESS HEAT

Proven a
thousand
times over:

The
LE air heater
family.

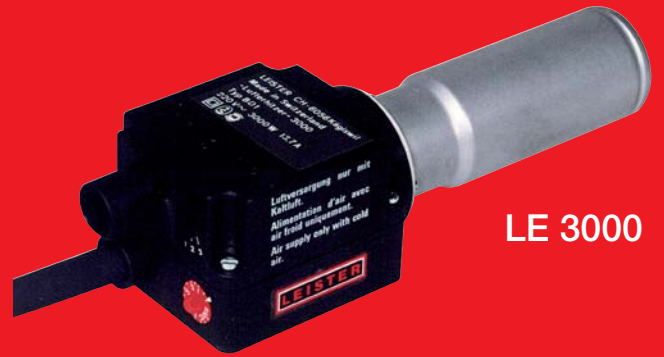

LE 3000



LE 3300

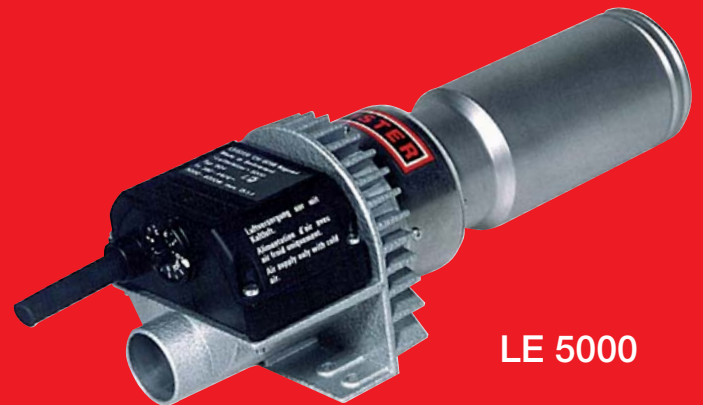

LE 5000



LE 10000 S

Leister delivers performances.

Wherever you need to apply heat, Leister provides the ideal solution. We have been the worldwide leader in the field of plastic welding and hot-air blowers for over 50 years. For several years now we have also been offering innovative and effective laser systems and micro-systems. We develop and produce all of our products in Switzerland – so you can always rely on the proverbial Leister quality. And because 98% of our production is exported, therefore, we have established a dense network of service centers throughout the world – guaranteeing excellent service anytime and anywhere.



Headquarters in Sarnen, Switzerland

LEISTER



Plastic Welding

For decades now, we have been the worldwide market leader. The proverbial performance and reliability of our products makes Leister the first choice. Our tools are used in roof sealing systems, floor coverings, plastic sheeting, in earthworks, hydraulic and tunnel engineering, in process equipment manufacturing and for vehicle repair.

NOVOLAS™

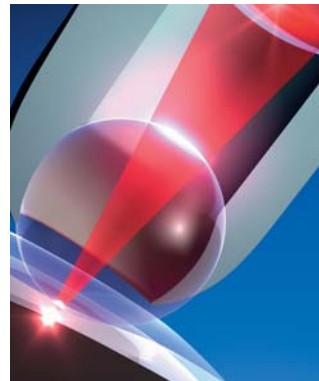

Lasersystems

Our innovative solutions for precision welding of plastics open up new production methods in automobile manufacturing, in medical and sensory technology, electronics, as well as in micro-systems technology or in soldering electronic components.

LEISTER



Process heat

Whether for activation, heating, curing, melting, shrinking, welding, sterilization, drying or warming: hot-air is increasingly deployed in industrial processes. Leister customers profit from our extensive engineering knowledge and benefit from our advice in the conceptual design of hot-air applications.

a:etris

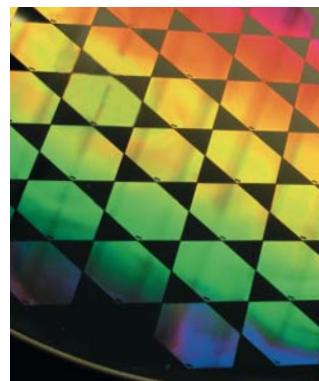

Microsystems

In tomorrow's world, the smallest of structures will play a huge role! In order for our customers to keep ahead of the field in the future, we are already developing and producing micro-mechanical sensors and micro-optical components in our cleanroom today.

LE 3000

The air heater LE 3000 is equipped with a performance range of 2.2 kW at 120 V, as well as 3.3 kW at 230 V. The air supply as well as air outlet connections are compatible with the successor LHS 20 and its accessories.

Air heater

LE 3000



Combination possibilities

Leister air heater with Leister blower at maximum heat power. Hot-air temperature 3 mm after air outlet, measured at the hottest point, at hose length 3 m and unimpeded air outflow. Air flow in l/min when air heater is not heated and air inlet temp. is 20 °C.

Power Type	Number LE × Power consumption W	Air flow l/min	Temperature °C
ROBUST	1 × 3300	1 × 400	530
ROBUST	2 × 3300	2 × 320	600

Air flow and temperature specifications may deviate from ideal values due to modifications of the hot-air system (nozzles, hose length, etc.).

Blowers and accessories in brochure “Industrial processes with hot air”.

Technical data LE 3000

	Without Electronic	With Electronic	For KSR DIGITAL
Heating power steplessly adjustable with potentiometer		•	
Thermoswitch for device protection	•	•	•
Integrated heating element protection		•	•
Remote control interface for KSR DIGITAL temperature regulator or external PLC control 2.6 – 5.8 V incl. 5 m cable and plug			•
Max. air outlet temperature °C	650	650	650
Min. air flow l/min. 120 V		200	
230 V	400	300	300
Max. air inlet temperature °C	100	50	50
Max. ambient temperature °C	100	60	60
Weight g	500	500	500
Mark of conformity	CE	CE	CE
Approval mark		Ⓢ	
Protection classe II	□	□	□

Voltage	V ~	120	230
Power consumption	kW	2.2	3.3
Without Electronic	Order no.		101.434
With Electronic	Order no.	101.436	101.426
for KSR DIGITAL	Order no.		101.382

Additional versions on request

Accessories in brochure “Industrial processes with hot air”, page 28

Installation dimensions in mm

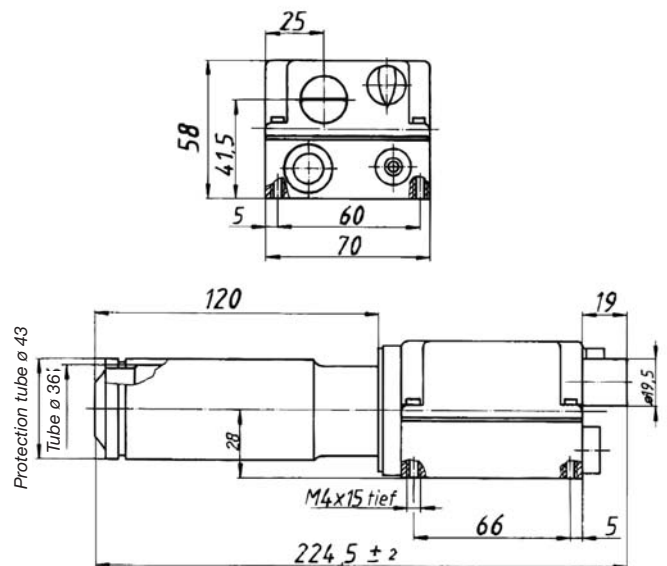

LE 3300

The air heater LE 3300 is equipped with a performance range of 2.2 kW at 120 V, as well as 3.6 kW at 230 V and 4.4 kW at 400 V. The air supply as well as air outlet connections are compatible with the successor LHS 40 and its accessories.

Air heater

LE 3300



Technical data LE 3300	Without Electronic	With Electronic	For KSR DIGITAL
Heating power steplessly adjustable with potentiometer		•	
Thermoswitch for device protection	•	•	•
Integrated heating element protection		•	•
Remote control interface for KSR DIGITAL temperature regulator or external PLC control 1.6 – 6.5 V incl. 5 m cable and plug			•
Max. air outlet temperature °C,	650	650	650
Min. air flow l/min.		150	
120 V		200	200
230 V		300	300
400 V	550	300	300
Max. air inlet temperature °C	100	50	50
Max. ambient temperature °C	100	60	60
Weight g	800	800	800
Mark of conformity	CE	CE	CE
Approval mark		Ⓢ	
Protection classe II	□	□	□

Voltage	V ~	120	230	400
Power consumption	kW	2.2	3.6	4.4
Without Electronic	Order no.		101.802	
With Electronic	Order no.	101.795	101.796	101.806
for KSR DIGITAL	Order no.		108.935	110.872

Additional versions on request

Accessories in brochure “Industrial processes with hot air”, page 28

Combination possibilities

Leister air heater with Leister blower at maximum heat power. Hot-air temperature 3 mm after air outlet, measured at the hottest point, at hose length 3 m and unimpeded air outflow. Air flow in l/min when air heater is not heated and air inlet temp. is 20 °C.

Power Type	Number LE × Power consumption W	Air flow l/min	Temperature in °C
ROBUST	1 × 3600	1 × 720	380
ROBUST	2 × 3600	2 × 450	490
SILENCE	2 × 3600	2 × 380	570
ASO	2 × 3600	2 × 580	530
ASO	4 × 4000	2 × 570	535
ASO	8 × 4000	8 × 560	550
AIRPACK	4 × 3600	4 × 800	350
AIRPACK	8 × 3600	8 × 400	450

Air flow and temperature specifications may deviate from ideal values due to modifications of the hot-air system (nozzles, hose length, etc.).

Blowers and accessories in brochure “Industrial processes with hot air”.

Installation dimensions in mm

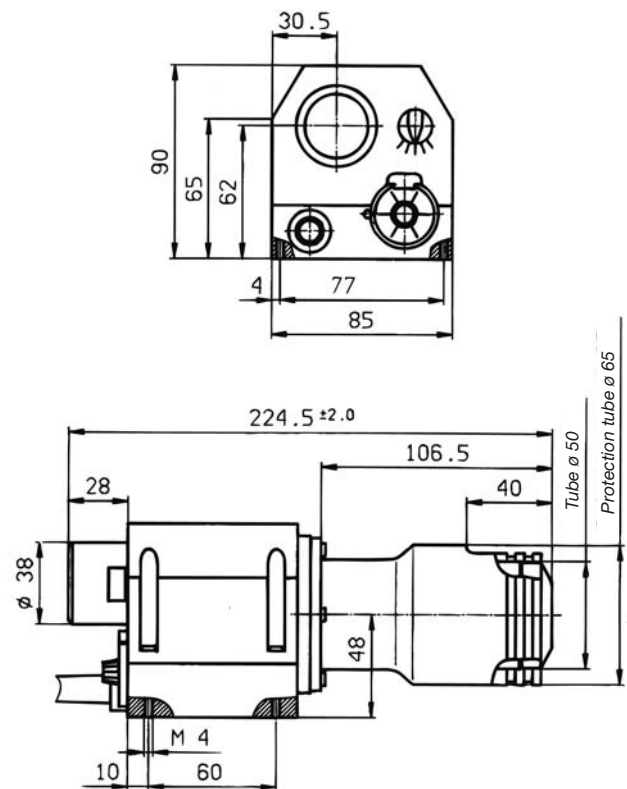

LE 5000

The air heater LE 5000 is equipped with a performance range of 4.5 kW at 230 V, of 5.5 kW and 8.5 kW at 400 V, as well as 8.0 kW at 480 V. The air outlet connections are compatible with the successor LHS 60S and its accessories. It is also available as a version for a supply temperature of up to 160°C, and is therefore especially suitable for recycling applications.

Air heater

LE 5000



Combination possibilities

Leister air heater with Leister blower at maximum heat power. Hot-air temperature 3 mm after air outlet, measured at the hottest point, at hose length 3 m and unimpeded air outflow. Air flow in l/min when air heater is not heated and air inlet temp. is 20 °C.

Power Type	Number LE ×	Air flow l/min	Temperature °C
	Power consumption W		
Silence	1 × 5000	1 × 870	560
Silence	2 × 5000	2 × 860	570
Silence	2 × 7500	2 × 1080	580
ASO	4 × 5000	4 × 1100	420
ASO	4 × 8000	4 × 1350	560
AIRPACK	4 × 5000	4 × 800	540
AIRPACK	6 × 5000	6 × 550	600

Air flow and temperature specifications may deviate from ideal values due to modifications of the hot-air system (nozzles, hose length, etc.).

Blowers and accessories in brochure “Industrial processes with hot air”.

Technical data LE 5000

	Without Electronic	With Electronic	For KSR DIGITAL
Heating power steplessly adjustable with potentiometer		•	
Thermoswitch for device protection		•	•
Integrated heating element protection		•	•
Remote control interface for KSR DIGITAL temperature regulator or external PLC control 2.4 – 5.8 V incl. 5 m cable and plug			•
Max. air outlet temperature °C,	700	700	700
Min. air flow l/min.			
230 V	450	400	400
400 V 5.5 kW	500	500	500
400 V 8.5 kW	700	900	900
480 V	700	900	900
Max. air inlet temperature °C	100	50	50
Max. ambient temperature °C	100	60	60
Weight kg	3.4	3.4	3.4
Mark of conformity	CE	CE	CE
Approval mark		Ⓜ	
Protection classe I	Ⓜ	Ⓜ	Ⓜ

Voltage	V ~	230	400	480
Power consumption	kW	4.5	5.5	8.5
Without Electronic	Order no.	102.160		102.180
With Electronic	Order no.	102.156	102.169	102.174
for KSR DIGITAL	Order no.			112.871
Without Electronic				
Supply air				
max. temp. 160 °C	Order no.		108.718	

Additional versions on request

Accessories in brochure “Industrial processes with hot air”, page 29

Installation dimensions in mm

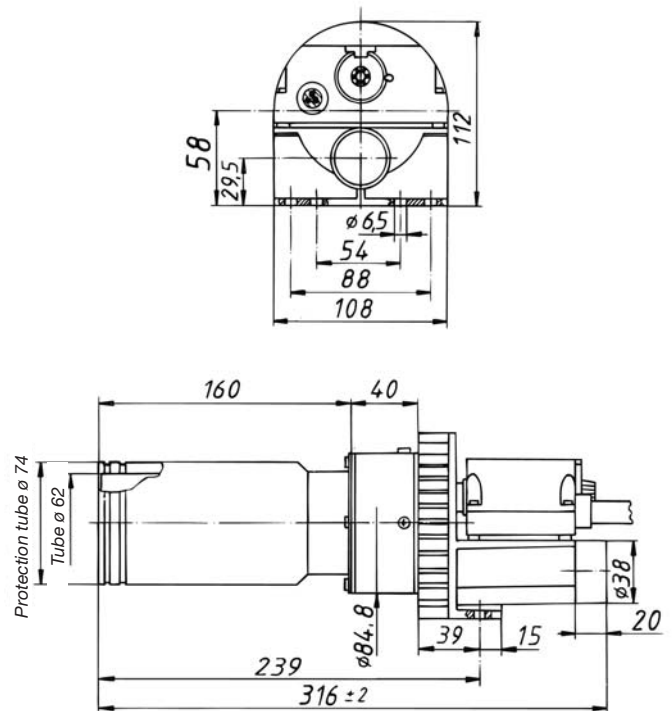

LE 10000 S

The air heater LE 10000 S is equipped with a performance range of 10 kW at 3 x 230 V, of 11 kW and 17 kW at 3 x 400 V, as well as 16 kW at 3 x 480 V. The air supply and air outlet connections are compatible with the successor LHS 60L and its accessories. The LE 10000 S is also available as a version for a supply temperature of up to 160°C, and is therefore especially suitable for recycling applications.

Air heater

LE 10000 S



Combination possibilities

Leister air heater with Leister blower at maximum heat power. Hot-air temperature 3 mm after air outlet, measured at the hottest point, at hose length 3 m and unimpeded air outflow. Air flow in l/min when air heater is not heated and air inlet temp. is 20 °C.

Power Type	Number LE × Power consumption W	Air flow l/min	Temperature °C
SILENCE	1 × 9500	1 × 2000	400
SILENCE	2 × 10000	2 × 1500	460
ASO	2 × 9500	2 × 2450	320
ASO	4 × 10000	4 × 2100	350
AIRPACK	2 × 10000	2 × 1600	440

Air flow and temperature specifications may deviate from ideal values due to modifications of the hot-air system (nozzles, hose length, etc.).

Blowers and accessories in brochure “Industrial processes with hot air”.

Technical data LE 10000 S

	Without Electronic	With Electronic	For KSR DIGITAL
Heating power steplessly adjustable with potentiometer		•	
Thermoswitch for device protection		•	•
Integrated heating element protection		•	•
Remote control interface for KSR DIGITAL temperature regulator or external PLC control 0 – 12 V incl. 5 m cable and plug			•
Max. air outlet temperature °C,	650	650	650
Min. air flow l/min. 10 and 11 kW	1700	1000	1000
16 and 17 kW	2200	1750	1750
Max. air inlet temperature °C	100	50	50
Max. ambient temperature °C	100	60	60
Weight kg	3.4	3.4	3.4
Mark of conformity	CE	CE	CE
Approval mark		Ⓢ	
Protection classe I	⊕	⊕	⊕

Voltage	V ~	3 × 230	3 × 400	3 × 400	3 × 480
Power consumption kW		10	11	17	16
Without Electronic	Order no.	102.753	102.768	102.770	102.779
with Electronic	Order no.	102.747	102.760	102.765	102.777
for KSR DIGITAL	Order no.		110.968		112.372
Without Electronic					
Supply air					
max. temp. 160 °C	Order no.			113.967	

Additional versions on request

Accessories in brochure “Industrial processes with hot air”, page 29

Einbaumasse in mm

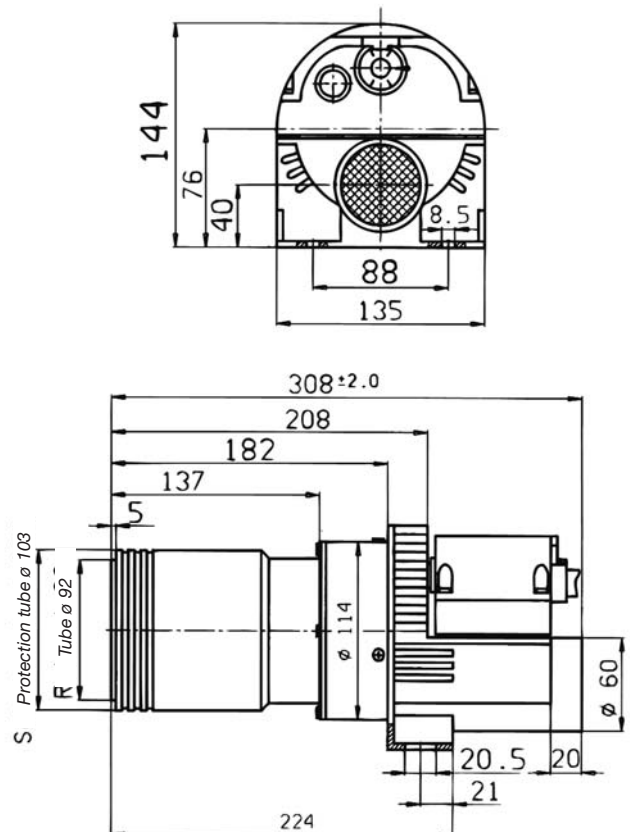

Temperature controller and separation amplifier

Leister hot air blowers as well as air heaters are integrated into the most various machines and plants. If the hot air temperature must be precisely measured, displayed and regulated in selectable steps, then the hot air device is by default equipped with a Leister KSR Digital (cascade regulator) and a thermo-element measuring sensor. The separation amplifier (interface) is necessary for the galvanic separation between an external target value voltage (leading voltage, external potentiometer) and the Leister air heaters Types 3000, 3300 and 5000.

Temperature controller

KSR DIGITAL



Technical Data	KSR DIGITAL
Regulation type	PID
Ready to use with preconfigured parameter set	•
Accuracy	Accuracy better than 0.2% of scale value at 25 °C
Switchover C° F°	Configurable via keypad
Temperature sensor / input	Type K / socket
Alarm output	2 alarms independently configurable Output at 2 floating relay contacts 2 mm receptacle
Connection to air heater	Socket, compatible with KSR models
Voltage	100 – 240 VAC, max. 8 VA
Mains connection lead	2 m, without plug
Mechanics	Regulator built into housing, ready to operate, can also be integrated into the front panel, with cut-out 67 x 67 mm
Size L x W x H	175 x 72 x 72
Weight g	500
Mark of conformity	CE
Protection classe II	□
Order no.	for LE 3000 230 V °C 110.340 for LE 3300 230 V °C 110.343 for LE 3300 400 V °C 110.344 for LE 5000 400 V °C 110.348 for LE 10000 3 x 400 V °C 110.359 for LE 10000 3 x 480 V °C 110.360

Interface

Interface



Technical dat	Interface	
This interface has to be used for reference voltage operation of LE 3000, LE 3300 and LE 5000		
Power consumption	mA	10
Input range	V DC	0 – 7.5
Output range	V DC	0 – 7.5
Size (L x W x H)	mm	165 x 60 x 80

Interface	Power supply voltage	V	120	230	400	480
for LE 3000 KSR	Order no.		129.564	129.565		
for LE 3300 KSR	Order no.			129.567	129.568	
for LE 5000 KSR	Order no.			129.569	129.570	129.571

Additional versions on request



®

Headquarters:

Leister Process Technologies
Riedstrasse
6060 Sarnen/Switzerland

phone: +41 41 662 74 74
fax: +41 41 662 74 16
leister@leister.com

www.leister.com

Leister Process Technologies is an **ISO 9001:2000** certified enterprise.

Specifications are subject to change without prior notice



UOur close worldwide network of more than 120 Sales and Service Centres in more than 60 countries.

© Copyright by Leister